

100kW Resistive Load Bank

With over **30 years** of load bank manufacturing, Crestchic support their load banks of varying sizes and age across the world.

Standard Features

- 1 Digital meter with USB-Type B dataport
- 2 Recessed control panel to protect controls
- 3 Voltage and temperature warning lamps
- 4 400 amp camlock power connections
- 5 Lightweight aluminum body
- 6 120V auxiliary power receptacle
- 7 Quiet, high-speed cooling fans



*Unit weight 64lbs

Details

Crestchic's 100kW load bank offers you a continuous load at 480/240/208 volts in a compact, ultra light-weight, indoor enclosure.

The digital meter allows you to measure power, voltage, current and frequency while also allowing you to record the data as you do your testing.

Power connections are easily done with our camlock connections. Auxiliary power of 120V is used for blower and control power. You should be up and testing within minutes of connecting your power source.

Cross Wire Resistors

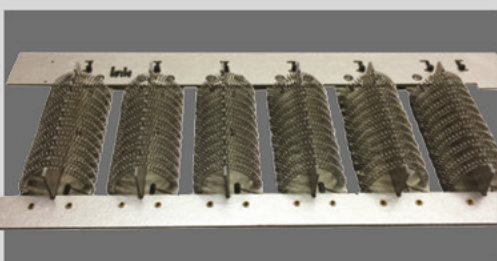

Our Cross Wire Resistor have no ceramics and therefore are lighter and more durable than any other resistor on the market today.

The resistors are supported by high temperature Mica supports that have been proven in Dynamic Braking Systems for locomotives and mining trucks all over the world.

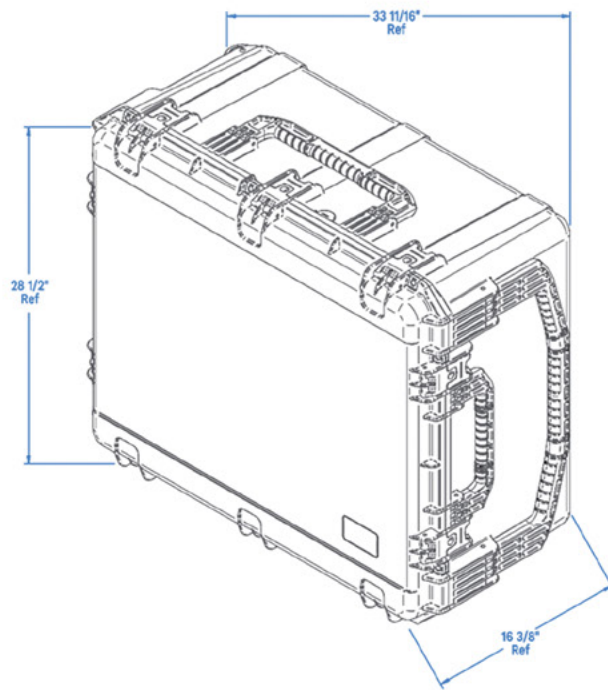
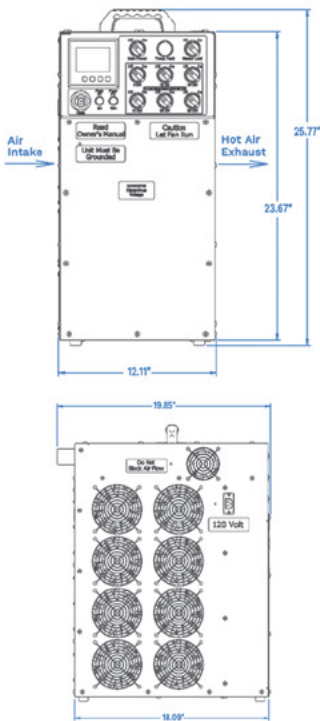

Specifications

KW	VOLTAGE	RESOLUTION
100	480	5
100	240	5
75	208	3.75
66	240/1	3.3
16.5	120/1	0.83

Standard Configuration

Digital Meter

- To measure current, voltage and frequency
- Data logging to store tests to laptop

Safety

- Over temperature and over voltage sensors
- Ground Camlock

Carrying Case

- 100% waterproof case Industrial strength injection molded case
- Gasket sealed, water and dust tight, submersible design
- Weight 38 lbs.

Control System



The **Multi-Unit Controller Software** is designed to help manage a single load bank or multiple load banks as one, and can be run on any laptop.

The hardware consists of an I/O card that is installed in each load bank. The controller can help manage a group of load banks to get the full load that is needed at the testing site.

AC Resistive Only Loadbanks

- Voltage 208 – 690V 3-Ph
- 1-Phase Option
- 10 – 7000kW
- 50, 60 or 400Hz
- 1.0pf
- 1kW resolution



AC Resistive-Reactive Loadbanks

- Voltage 208 – 690V 3-Ph
- 1-Phase Option
- 50 - 6250kVA
- 50, 60 or 400Hz
- Fixed or Variable Power Factor
- 1kW resolution



Step-Up/ Step-Down Transformers

- 400V – 36kV
- 2000 – 8000kVA
- MV & LV Switchgear
- ONAN/ONAF Variants



DC Loadbanks

- 24 – 1000V DC
- Amps or kW resolution
- Single or Multi-Voltage Units



Medium Voltage Loadbanks (up to 36kV)

- Voltage 690 – 36kV 3-Ph
- 500 – 3500kVA
- 500 – 4000kW
- 50 or 60Hz
- Unity or Variable pf



AC Reactive Only Loadbanks

- Voltage 208 – 690V 3-Ph
- 1-Phase Option Available
- 10 – 1800kVAr
- 50 or 60Hz



Aviation Ground Power Generator Loadbanks

- Voltage 200 – 208V 3-Ph
- 72 – 160kW
- 90 – 200kVA
- 400Hz
- Unity or 0.8pf



For further information contact:
CRESTCHIC INC USA,
 9535 Swafford Road
 Justin TX 76247
 United States of America

Cell: +1 (817) 716-2623
 E: Rental-USA@crestchic.com
 E: Sales-USA@crestchic.com
www.crestchic-usa.com

The information given in this literature is, to the best of our knowledge, correct at the time of going to print. However, Crestchic is constantly looking at ways of improving their products and services and therefore reserve the right to change, without prior notice, any of the data contained in this publication. Any orders placed will be subject to our Standard Conditions of Sale, available on request.